

What's New in GDPS

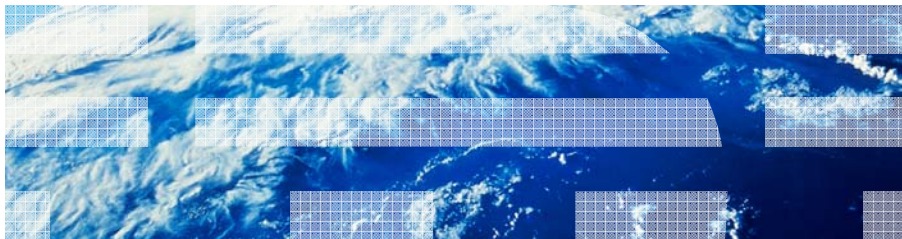

Agenda



➔ Evolution into an Enterprise Wide Solution

- GDPS V3.7 Enhancements
 - Improved coordinated disaster recovery across heterogeneous platforms
 - Improved scalability
 - Increased availability
 - Simplified system management
- Statements of Direction (SODs)
- Summary

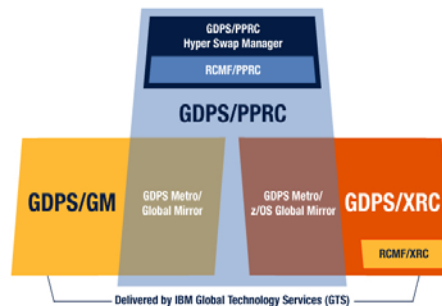

Aspects of IT Business Continuity

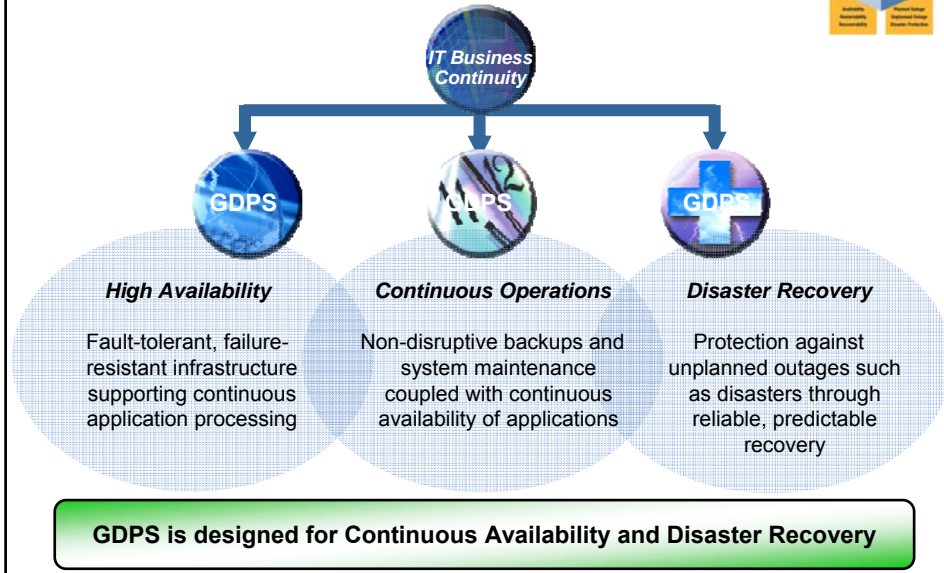

Evolution into an Enterprise Wide Solution

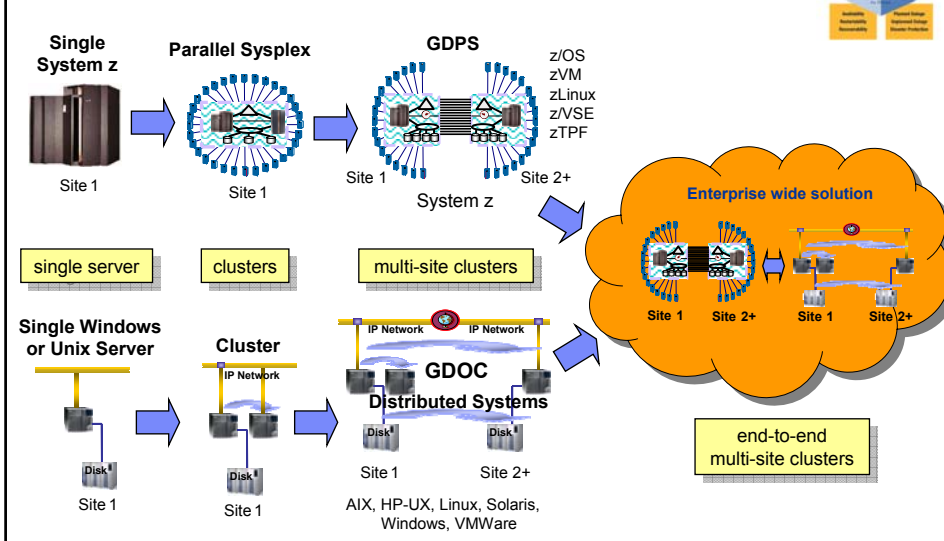

GDPS = Geographically Dispersed Parallel Sysplex

GDOC = Geographically Dispersed Open Clusters

System z Business Continuity Architecture

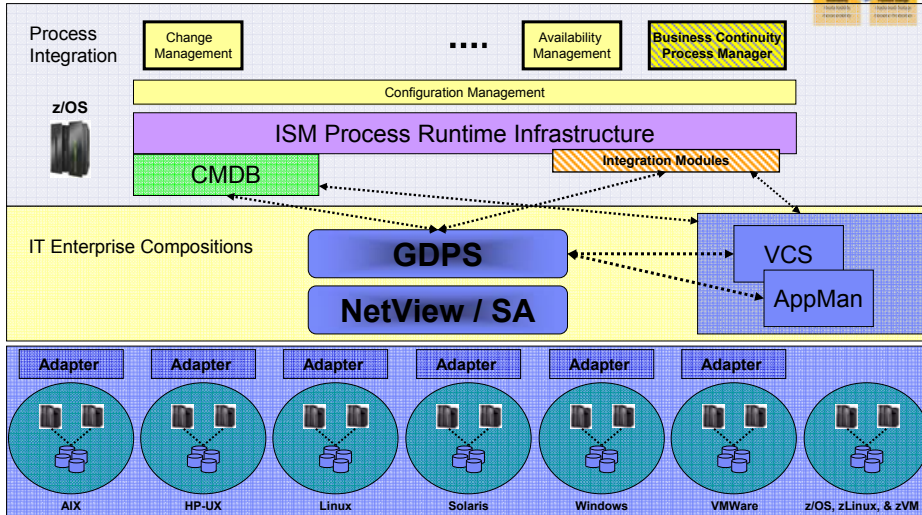

GDPS technology is central to managing System z BC extensions

PPRC, XRC and GM Overview

Metro Mirror (PPRC)

- Synchronous remote data mirroring
- Metropolitan Distance
- System z and distributed data
- GDPS/PPRC provides data consistency

z/OS Global Mirror (XRC)

- Asynchronous remote data mirroring
- Unlimited distance support
- System z data
- System Data Mover (SDM) provides data consistency

Global Mirror

- Asynchronous remote data mirroring
- Unlimited distance support
- System z and distributed data
- Global Mirror provides data consistency

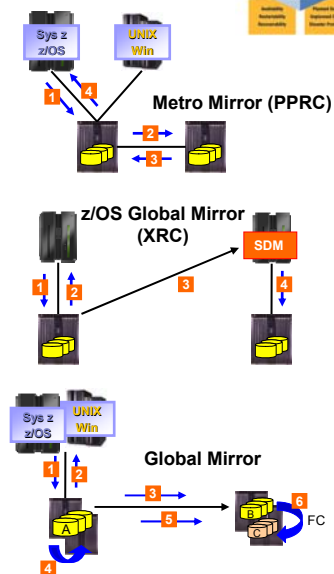

The GDPS® family of offerings
 The right level of business continuity protection for your business



GDPS: an end-to-end continuous availability and disaster recovery solution:

- Automated recovery removes people as Single Point of Failure
- A single point of control for heterogeneous data across enterprise

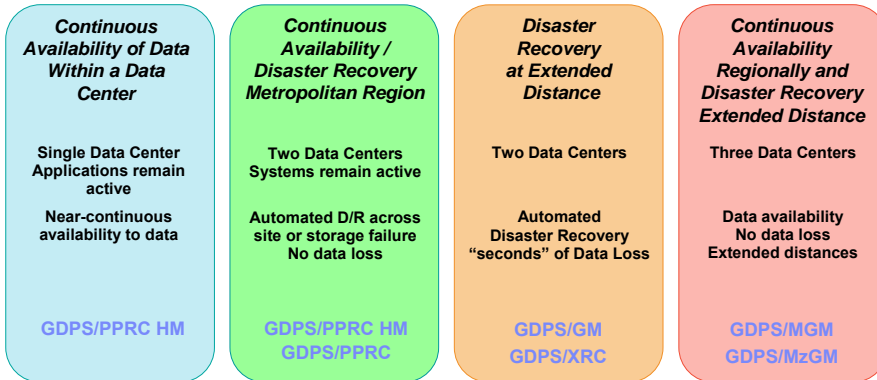

GDPS/PPRC HyperSwap Manager



**Maximum resilience for z/OS data in a single site
 Entry-level disaster recovery across two sites**

- GDPS automation runs on all systems sharing the PPRCed disks
- Manages PPRC – System z and Open data
 - Cannot HyperSwap Open Data; Open data will be "frozen" to maintain data consistency
- Unplanned, autonomic actions
 - Manages secondary data consistency in the event of mirroring failures
 - Invokes HyperSwap if primary disk fails
 - Protects data integrity during the swap GDPS will kill systems that fail to swap
- Planned, user initiated actions
 - HyperSwap to switch disks

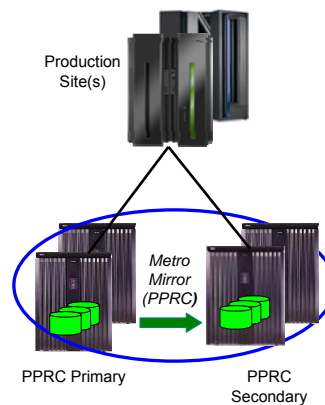

GDPS/PPRC: a Continuous Availability and/or Disaster Recovery Solution - Metropolitan Distance



- Manages Multi-Site Parallel Sysplex, Processors, CBU, CF, Couple Data Sets
- Manages Disk RC (System z & open LUN)
- Manages Tape Remote Copy (PtPVTs)
- Exploits Hyperswap & FlashCopy Function
- Automated, customized procedures to execute planned and unplanned actions (z/OS, CF, disk, tape, site)
- Improves availability of heterogeneous System z business operations

Planned and unplanned exceptional conditions

GDPS - Freeze Policy Options



- | | |
|---|---|
| <p>FREEZE & GO</p> <ul style="list-style-type: none"> ▪ Freeze secondary disk configuration ▪ Allow applications to continue <ul style="list-style-type: none"> – Optimize for remote restartability – Least impact on application availability – May lose data in case of real disaster | <p>FREEZE & STOP</p> <ul style="list-style-type: none"> ▪ Freeze secondary disk configuration ▪ Stop all z/OS images <ul style="list-style-type: none"> – Optimize for remote restartability – Impacts application availability – No data loss on primary site disaster |
| <p>FREEZE & COND</p> <ul style="list-style-type: none"> ▪ Freeze secondary disk configuration ▪ Determine reason for suspend <ul style="list-style-type: none"> – If secondary HW problem then Freeze & Go – Other reason: Freeze & Stop | <p>SWAP, [GO STOP]</p> <ul style="list-style-type: none"> ▪ If Swap trigger and HyperSwap enabled <ul style="list-style-type: none"> – Swap primary / secondary disks – If swap cannot complete, STOP ▪ Else (Freeze trigger) <ul style="list-style-type: none"> – If GO option: Freeze & Go – If STOP option: Freeze & Stop |

Business Continuity Metrics RPO (data loss) and RTO (downtime)



Timeline of a Recovery

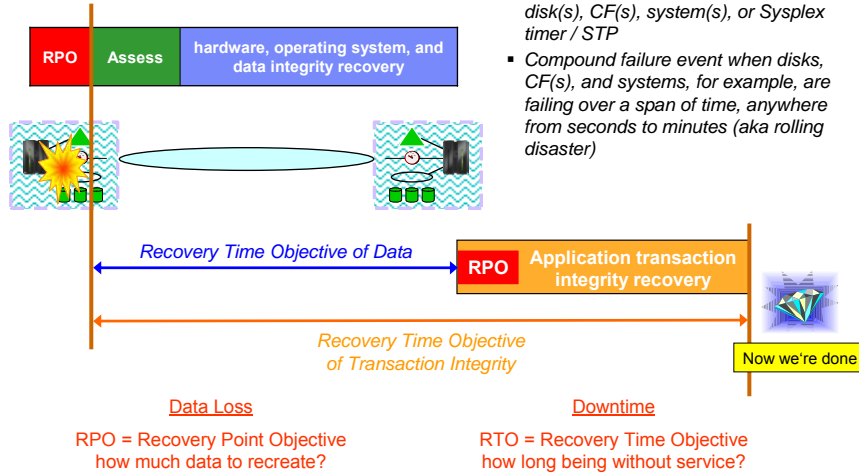

- Single component failure, for example, disk(s), CF(s), system(s), or Sysplex timer / STP
- Compound failure event when disks, CF(s), and systems, for example, are failing over a span of time, anywhere from seconds to minutes (aka rolling disaster)

GDPS/PPRC active/standby – Single Site Workload Near Continuous Availability Solution

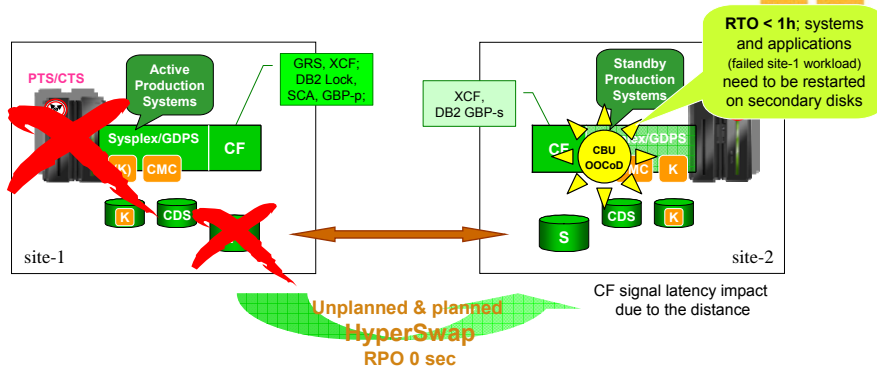

**Continuous access to data via HyperSwap
Highly automated site failover in the event of catastrophic systems,
multiple components or data center failure**

GDPS/PPRC active/active – Multi-Site Workload Configuration with most potential for continuous availability

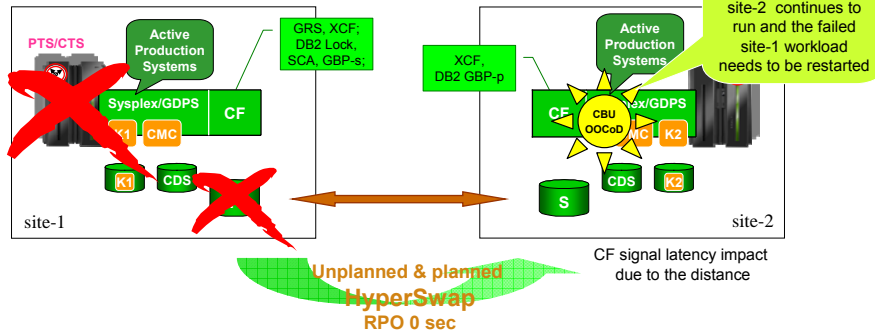

**Continuous access to data via HyperSwap
Highly automated site failover – failing site-1 operating systems and applications need to be recycled**

Cross-site Sysplex – GDPS/PPRC active / active - GDPS CA Model

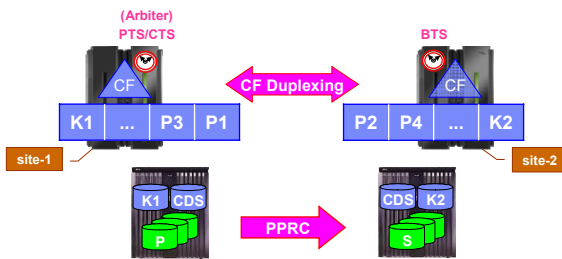

CA in the event of catastrophic system involving multiple components or data center failure AND D/R within metropolitan distance

- **RTO = 0**; the surviving site continues to run and the failed site's workload needs to be restarted to release shared resources
- **RPO = 0**; no data loss
- Potential application impact due to CF signal latency (access rate, distance)

All critical data must be PPRCed and HyperSwap enabled
All critical CF structures must be duplexed
Applications must be parallel sysplex enabled

Time reference must not be lost

Failures in one site do not cause applications running in the other site to fail



GDPS/PPRC Timer Support

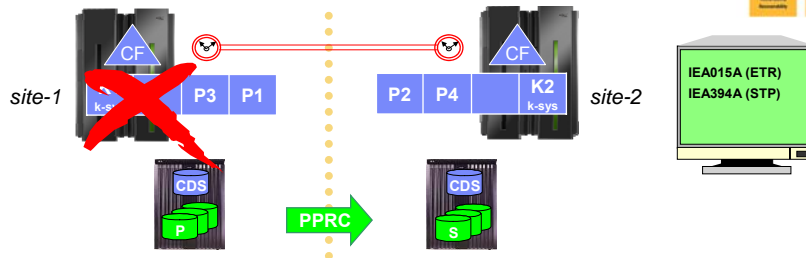

- Allows K-sys to continue processing even when time source lost
- Puts Ksys into local timing mode up to 80 minutes
 - to complete any Freeze or HyperSwap in progress
 - Aid with situation analysis before replying to sync WTORs (DCCF)
 - XCF APAR OA32236 to disable SFM actions on Ksys
- GDPS/PPRC and GDPS/HM V3.6+, z/OS R11 (rollback to R9)

Protects K-sys if loss of timing source

Primary Site Failure - first indicator of an outage



- 1 PPRC failure might be the sign of a rolling disaster in the primary site, however ...
 - practically, all PPRC failures are false freezes – aka false alarms (non-DR events)
 - very unlikely that recovery on the secondary disks will be required
- 2 Primary write failures are rarely false alarms
 - Usually either primary disk is broken (single component failure) or could be the sign of a compound failure (e.g., rolling disaster)

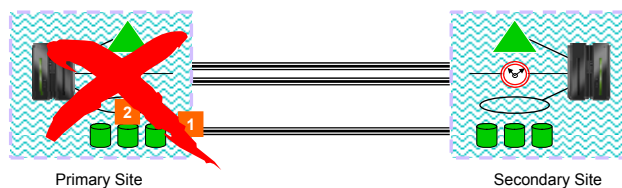

Enhanced Recovery Support for CF Duplexing (aka CF Hint)

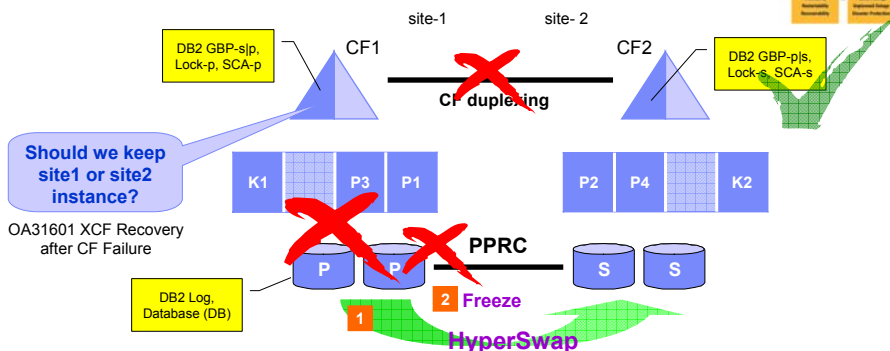

OA31601 XCF Recovery after CF Failure

DB2 Log, Database (DB)

- Requires Freeze=STOP policy - (SWAP,STOP) or (FREEZE,STOP)
- Structure in same site as secondary disks be retained
- Provides time-consistency between CF structures and disks

**No special recovery actions required (GRECP)
Facilitates faster application restart (RTO)
Provides consistent recovery time**

Cross-site Sysplex – GDPS/PPRC active / active - GDPS CA Model (CF in 3rd site)

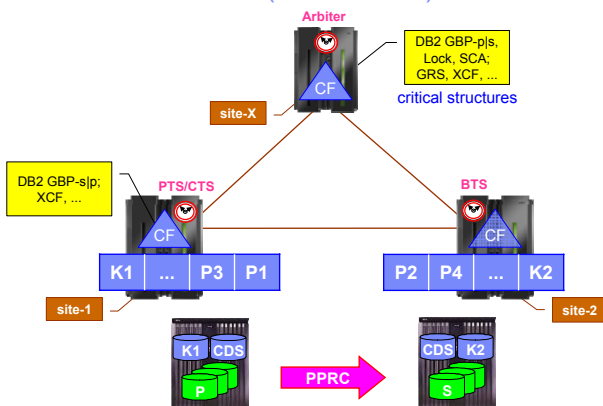

All critical data must be PPRCed and HyperSwap enabled
Applications must be parallel sysplex enabled

State of the art of System z configurations

- RTO = 0**; the surviving site continues to run and the failed site's workload needs to be restarted to release shared resources
- RPO = 0**; no data loss
- No application impact since CF signal latency impact is mitigated





GDPS/XRC Long distance failover for System z only

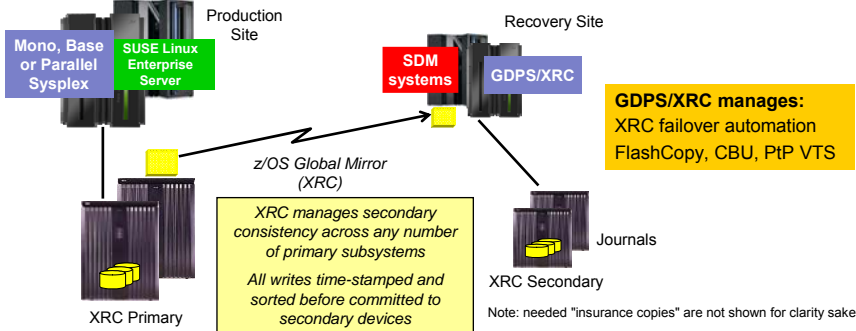

- **Manage XRC**
- **Manage SDMs**
- **Manage FlashCopy**
- Virtually unlimited distance
- Once initiated, **totally automated failover**
 - **Recovery** of secondary disks
 - **Activation** of CBU
 - **Shut down** SDM / discretionary LPARs
 - **Reconfiguration** of the recovery site servers
 - **Restart** of production systems in the recovery site



GDPS/Global Mirror Long distance failover for System z and Open

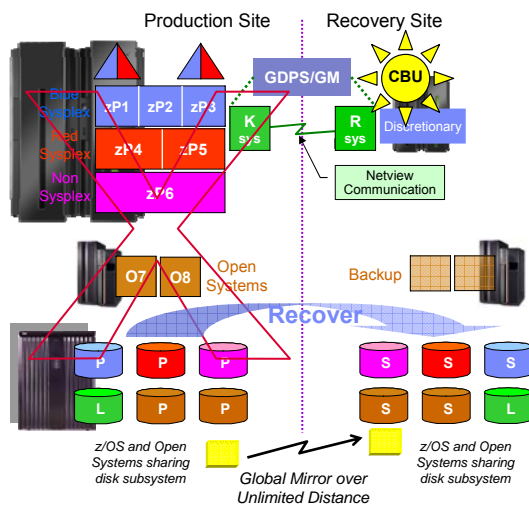

- Production site can have single z/OS systems, Open systems, systems in a Sysplex
- All data (z/OS and Open Systems) is planned to be mirrored using Global Mirror
- **K-sys** activities
 - manages multiple Global Mirror sessions
 - sends device information, scripts, alerts to R-sys
- **R-sys** activities:
 - secondary disk recovery, CBU activation, activate backup LPARs, IPLs systems
- **Time consistent data** at the recovery site

GDPS 3-site Solutions

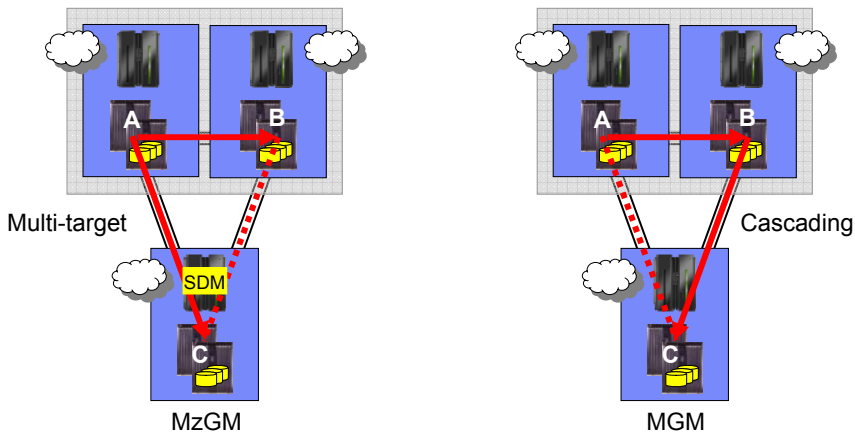

A GDPS 3-site solution combines both GDPS/PPRC or GDPS/PPRC HM and one of GDPS/XRC or GDPS/GM

GDPS/MzGM configuration

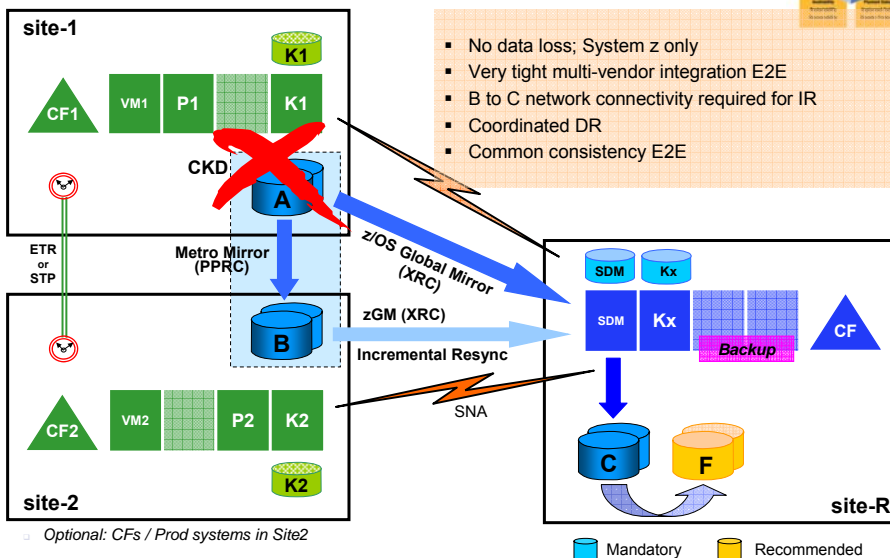

- No data loss; System z only
- Very tight multi-vendor integration E2E
- B to C network connectivity required for IR
- Coordinated DR
- Common consistency E2E

Optional: CFs / Prod systems in Site2

Open LUN Management

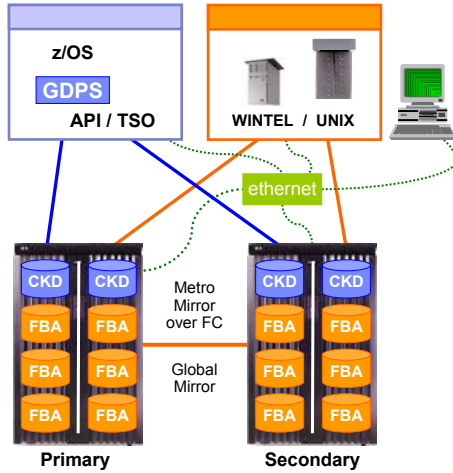

- Data consistency across z/OS and open systems
- GDPS single point of control
- Supports cross-platform or platform level Freeze
 - Suspends reported through SNMP alert
- GDPS/PPRC, GDPS/PPRC HM and GDPS/GM

Helps provide enterprise-wide Disaster Recovery with Data Consistency

GDPS/PPRC Multiplatform Resiliency for System z (xDR) - Architectural Building Blocks

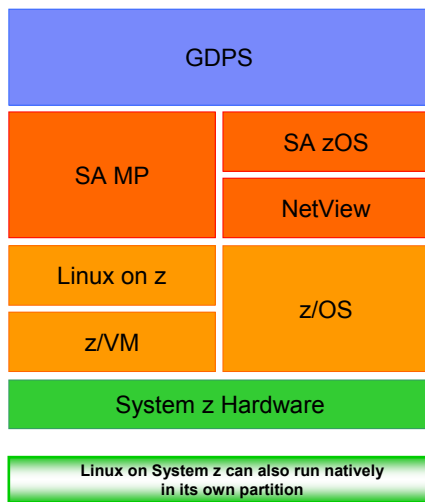

Business Continuity solution for z/OS and Linux applications on System z

- Leverage of existing and proven solutions
 - GDPS
 - SA z/OS
 - IBM Tivoli System Automation for Multiplatform (SA MP)
- Coordinated cross platform business resiliency for operating systems (OS) running on System z hardware
- Integration point of z/OS and Linux on System z

xDR Guest Linux Clusters

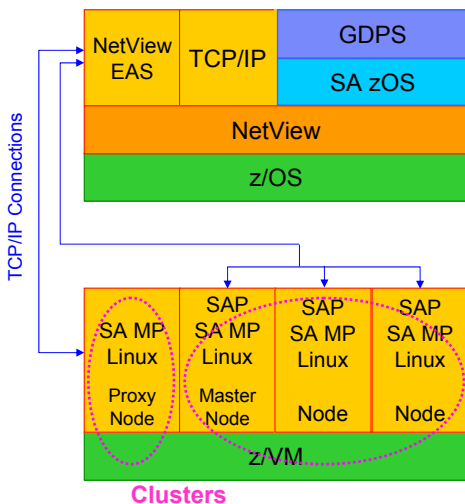

- Multiple z/VM systems supported
 - z/VM guests running Linux & SA MP
- Proxy Guest used by GDPS to communicate commands to z/VM and to monitor for disk errors
 - Is a cluster of just one node
- A second cluster made up of multiple nodes
 - One node will be the master
 - All guests run an application workload, e.g., SAP
- TCP/IP connections between the Linux guests and Netview Event Automation Address Space (EAS) are used to inform GDPS of
 - Their existence
 - Their ongoing presence, and
 - Any change in their status

HyperSwap Triggers



- **Hard Failure Triggers**
 - I/O errors
 - Boxed devices
 - Control Unit failures
 - Loss of all channel paths
- **“Soft Failure”- I/O response time triggers**
 - z/OS (IOT threshold)
 - z/VM and z/VM guests, including Linux guests
- **Dual site and single site environments**
 - GDPS/PPRC
 - GDPS/PPRC HyperSwap Manager

GDPS/PPRC only

Improved availability

GDPS/PPRC Multi Platform Resiliency for System z (aka xDR)

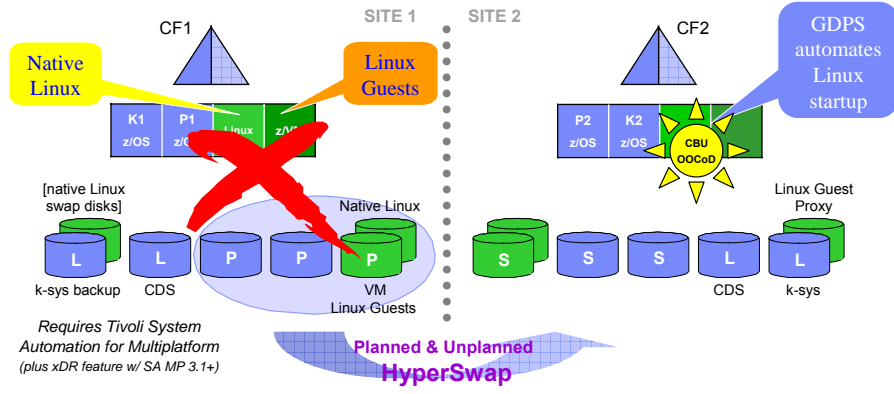

Coordinated near-continuous availability and DR solution

xDR graceful shutdown for z/VM (2Q2010)



- Orderly shutdown of z/VM LPARS (guests and z/VM)
 - STOP Standard Action
 - SYSPLEX STOP script statement extended
- Similar automation to z/OS LPARS
- Prerequisites
 - GDPS PPRC 3.7 with SOCKETS communication protocol
 - SAMP 3.2 or higher
 - z/VM APARs VM64783 and VM64787 and changed z/VM Setup

Less manual interactions

Support for mirroring swap disks (xDR native)



- Linux swap disks mirrored using Linux “md-raid” technology
- Avoids need to stop processes prior to HyperSwap
- Prerequisites
 - SUSE SLES 10 SP3, SUSE SLES 11 GA
 - SAMP 3.1 FP1 or higher

Improved availability

Distributed Cluster Management (DCM)



- **“End-to-end recovery solution”**
 - Management and coordination of System z and distributed servers using clustering solutions
 - Veritas Cluster Server (VCS)
 - Tivoli System Automation Application Manager (SA AppMan)
 - Planned and unplanned
- **Advisory**
 - Continuous status gathering and information passing
 - Heartbeats, Alerts
 - Service Groups, Clusters
 - Cross notifications for planned and unplanned downtime
 - SA AppMan / VCS and GDPS take respective necessary actions
- **Coordination**
 - Workflow integration
 - Usage of GDPS Scripting Language
 - Active cross-monitoring
 - Fire-drill group support



Integrated, Automated, Industry-unique

GDPS (PPRC/XRC/GM) DCM for VCS Windows support added (GA 1H2010)



CA / DR within a metropolitan region

Two data centers - systems remain active; designed for no data loss

DR at extended distance

Rapid systems recovery with only "seconds" of data loss

DR at extended distance

Rapid systems recovery with only "seconds" of data loss

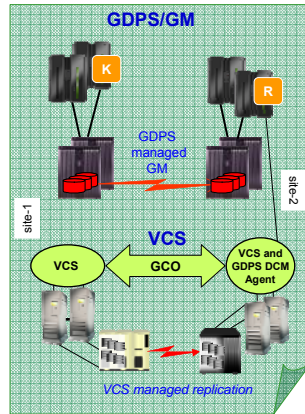
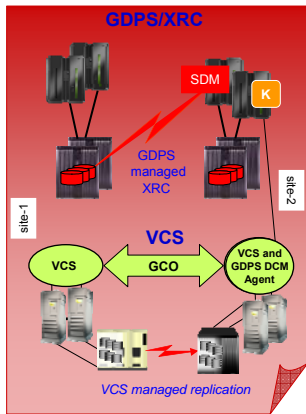
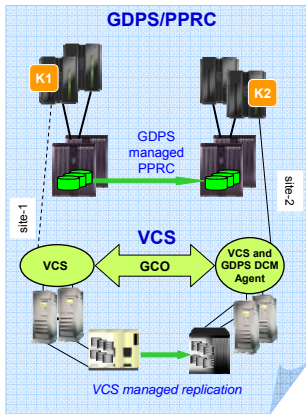

GDPS/DCM Support for SA AppMan

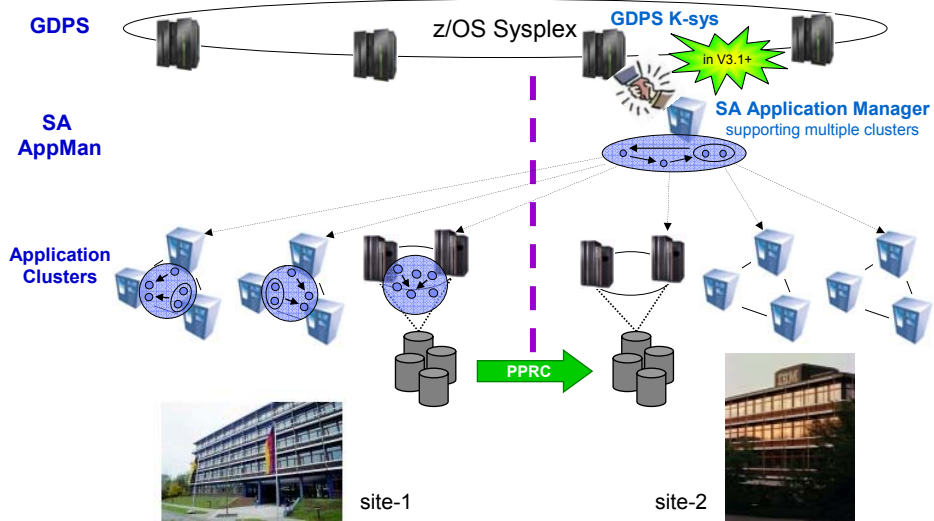



Agenda

- Evolution into an Enterprise Wide Solution
- GDPS V3.7 Enhancements
 - Improved coordinated disaster recovery across heterogeneous platforms
 - Improved scalability
 - Increased availability
 - Simplified system management
- Statements of Direction (SODs)
- Summary

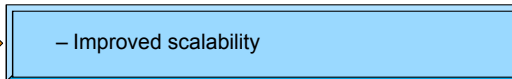

Alternate Subchannel sets for PPRC secondary disk support

- z/OS subchannels used for
 - Primary disk
 - Secondary disk
 - FlashCopy versions
 - (some for PAVs)
- Allows up to nearly 64,000 pairs
- Prerequisites:
 - z/OS 1.10 or higher
 - z9 or z10 servers
 - GDPS/PPRC (or HM) systems at 3.7 level
- *Large devices still recommended way to reduce UCBs*

PPRC secondaries in alternate logical subchannel set

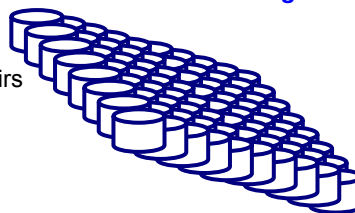

Allows larger disk configuration



Agenda

- Evolution into an Enterprise Wide Solution
- GDPS V3.7 Enhancements
 - Improved coordinated disaster recovery across heterogeneous platforms
 - Improved scalability
 - Increased availability
 - Simplified system management
- Statements of Direction (SODs)
- Summary

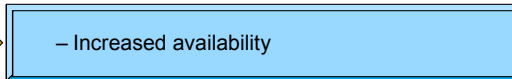

Reduced impact copy for Metro Mirror Support extended to LUNs

- Reduced impact for initial copy and resynchronization
- Exploits Global Copy (PPRC-XD)
- Starts in asynchronous mode (GC)
- Switches to synchronous mode (MM) when volumes near full duplex

- CKD support available in GDPS 3.6 base
- FB support available in 3.7 (base) and 3.6 (via SPE APAR)
- GDPS/PPRC; GDPS/PPRC HyperSwap Manager

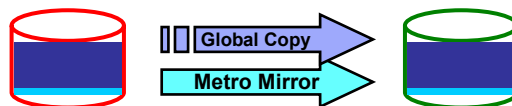

Virtually eliminates production workload impact during initial copy of resynchronization of Metro Mirror

Reduced-impact copy benchmark

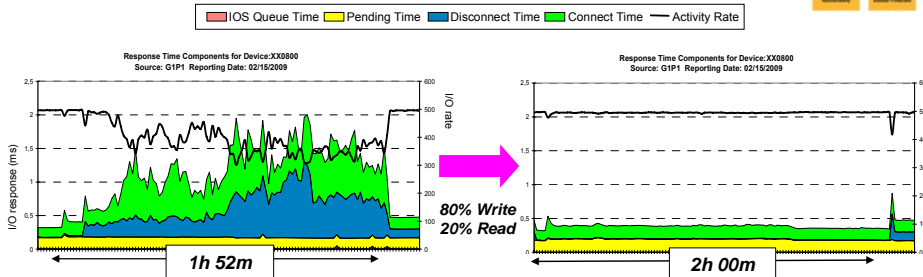

Previous Copy

- High impact on response time
- Impact on I/O rate for almost all the duration of Start Secondary

Reduced Impact Copy

- Negligible impact on response time
- Negligible impact on I/O rate and throughput

Allows flexibility when scheduling initial copies and resynchronizations

Preserve Mirror Tool (PMT)



- Starts PPRC and brings new devices to duplex state before they are added to GDPS configuration
- Keeps Freeze and HyperSwap ready during initial copy
- Highly automated process
- Exploits Global Copy (PPRC-XD) to reduce impact
- "As is" tool for GDPS 3.6 and higher
- GDPS/PPRC and GDPS/HM

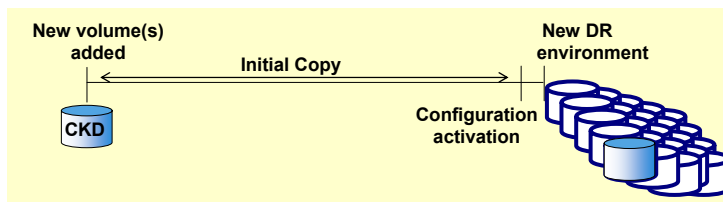

Reduces CA / DR exposure when adding volumes

Remote Pair FlashCopy support



- GDPS/PPRC and GDPS/PPRC HM
- New Freeze trigger added
 - IEA494I dev,volser PPRC PAIR SUSPENDED FC
 - IEA491E dev,volser SUSPENDED, ESTABLISH/WITHDRAW FLASHCOPY WITH PRESERVE MIRROR FAILED
- Available in GDPS 3.7 (base) and GDPS 3.6 (via SPE APAR)
- Best practices guidelines for including GDPS-managed PPRCed FlashCopy target devices documented in GDPS 3.6.1 manual

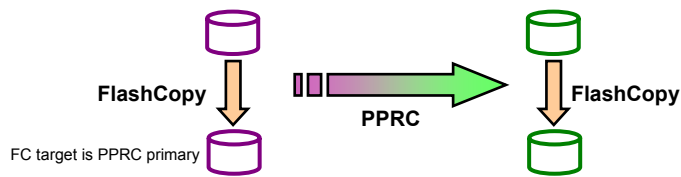

Combines value of HyperSwap with numerous values of FlashCopy

GDPS/MGM Incremental Resync Tool



- NetView REXX code - can be integrated into GDPS scripts as USERPROCs
- Already supported: when running A-B-C, after B-disk outage, incrementally resync A-C

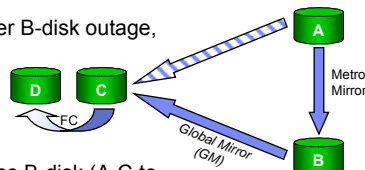

- 1H10
 - New – Part 1: when running A-C, reintroduces B-disk (A-C to A-B-C incrementally)
- 2H10
 - New – Part 2: Planned swap (flip/flop) between A-disk & B-disk (A-B-C to B-A-C back) with incremental resync to C

Protects recovery environment & provides operational flexibility

GDPS/MGM Incremental Resync Tool

1H10

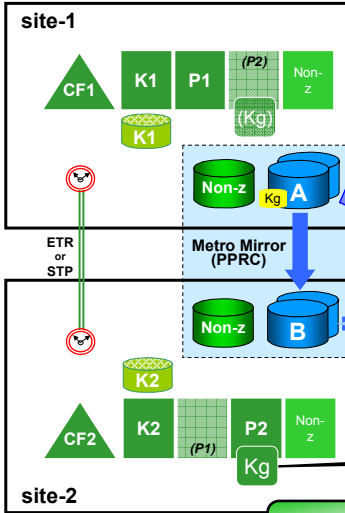

- Continue to have DR protection while restoring B copy
- Incremental copy when B disk available
- Can avoid full volume copies
- Reduces exposure from hours to minutes

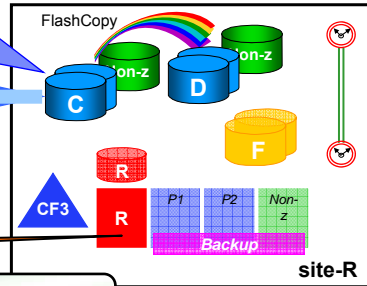

Protects recovery environment

GDPS/MGM Incremental Resync Tool

2H10

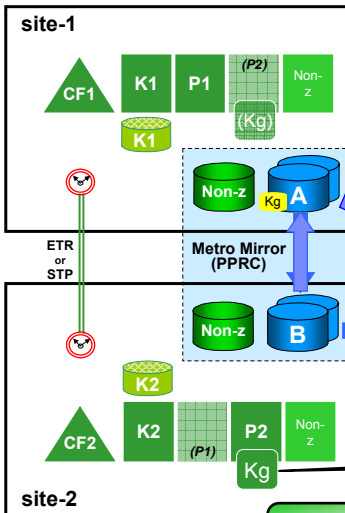

- Planned swap (flip/flop) between A-disk and b-disk
- A-B-C to B-A-C and back with incremental resynch to C

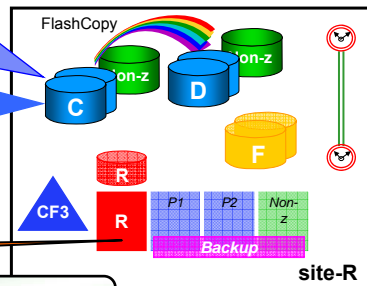

Operational Flexibility

Agenda



- Evolution into an Enterprise Wide Solution
- GDPS V3.7 Enhancements
 - Improved coordinated disaster recovery across heterogeneous platforms
 - Improved scalability
 - Increased availability



– Simplified system management

- Statements of Direction (SODs)
- Summary

Simpler installation, fewer manual definitions



- GDPS and System Automation together:
 - Automatically determines how many batch operators are needed
 - Automatically defines them
- Based on number of LSS pairs defined in GEOPARM
 - Just need to define “model” definition once
- Synergy with System Automation (3.2 and higher)
- GDPS/PPRC and GDPS/HM 3.7

Eliminates unnecessary manual installation definitions in SA policy



GDPS/PPRC HM GUI support extended (2Q2010)



- GDPS GUI currently supported with
 - GDPS/PPRC
 - GDPS/GM
 - GDPS/HM when using **full function** NetView product

- GUI interface now supported with NetView for GDPS/PPRC HM
 - IBM Tivoli System Automation for GDPS/PPRC HyperSwap Manager with NetView V5.4

Provides GUI interface with GDPS/PPRC HM and System Automation for GDPS/PPRC HM with NetView



New Query Services ENVIRONMENT query



- Queries on GDPS monitored resources
 - **Systems** z/OS images within this GDPS-Plex
 - **DASD** Primary and secondary disk and SSIDs
 - **HyperSwap** HyperSwap related information
 - **Monitors** Monitor statistics
 - **Environment** General information about the GDPS environment
 - **All** All of the above

- Returns information about the GDPS 'environment'
 - GDPS product Version/Release
 - GEOPARM dataset/member name Freeze action
 - CKD/FB disk last config load time etc

- Available in GDPS 3.7 (base) and 3.6 (via SPE APAR)
- GDPS/PPRC and GDPS/PPRC HM

Allows customer to extend GDPS automation with their own

BPCii Suspend/Resume Support



- Suspend/resume BCPii session with a given CPC as planned action
 - New CPC Operations option from Standard Panel
 - GDPS/PPRC, GDPS/XRC, GDPS/GM
- Status provided for all CPCs known to GDPS
- Option on CPC Operations panel to SUSPEND or RESUME BCPii for a given CPC
- Available in GDPS 3.7 (base) and GDPS 3.6 (via SPE APAR)

For planned maintenance on CEC

Agenda



- Evolution into an Enterprise Wide Solution
- GDPS V3.7 Enhancements
 - Improved coordinated disaster recovery across heterogeneous platforms
 - Improved scalability
 - Increased availability
 - Simplified system management



▪ **Statements of Directions**

- Dates
- SODs

- Summary

Dates



The planned availability is June 30, 2010, for:

- GDPS/MGM Incremental
- Resynchronization tool
- xDR enhancements
- Distributed Cluster Management (DCM) support extended to Microsoft Windows clusters
- SUSE SLES11 support

SOD: Freeze policy simplification



- Allows more control over GDPS/PPRC and GDPS/PPRC HyperSwap Manager actions after disk subsystem events
- Split freeze policy into 2 parts
 - PPRC failure action triggered by PPRC suspension events
 - GO, STOP or COND
 - Primary device failure
 - SWAP, GO or STOP
 - For SWAP, additional action (GO or STOP) if HyperSwap disabled
- Consistent handling of triggers
 - Always treated as primary failure trigger:
 - IOS002A no paths available
 - IEA491E with primary device write failure indication

All statements regarding IBM's future direction and intent are subject to change or withdrawal without notice, and represent goals and objectives only.

SOD: z/VM Timestamps for guests



- z/VM to generate time-stamps on all guest and system disk I/O operations, and provide limited (host-only) exploitation of the Server Time Protocol (STP) facility to ensure time consistency
- Allows z/VM to participate in GDPS solutions (GDPS/XRC and GDPS Metro/z/OS Global Mirror (GDPS/MzGM)) that use the IBM System Storage z/OS Global Mirror asynchronous mirroring technology

All statements regarding IBM's future direction and intent are subject to change or withdrawal without notice, and represent goals and objectives only.

SOD: Enhanced Sysplex Timer / STP support



- GDPS/PPRC and GDPS/HM
- Available in z/OS 1.11 base (via SPE APAR in z/OS 1.9 and 1.10)
- Currently, z/OS recognizes that a system is a Ksys
 - Puts Ksys into local timing mode up to 80 minutes - instead of spinning with sync WTOR (DCCF message)
 - Allows Ksys to continue processing even when time source lost and to complete Freeze or HyperSwap, and to run scripts as required
 - Facilitates situation analysis before replying to WTORs on prod systems
 - Review status of PPRC and other resources
 - Remove 'guessing game' about whether safe and which systems to restart
- **XCF OA32236 to disable SFM actions on Ksys (available 5/2010)**
- Basis for follow-on enhancements
 - Ksys automatically replies to DCCF messages
 - Ksys script statements to reconfigure STP



All statements regarding IBM's future direction and intent are subject to change or withdrawal without notice, and represent goals and objectives only.

Attention!!!



- GDPS 3.7 is the last release that will support
 - P/DAS
 - Network Management functions
 - “Activate method” for IPLing systems
 - LOAD will remain the only supported method

- GDPS 3.8 will be the last release that will support
 - Policy switching method for managing CFs
 - Single policy (INGCFL interface) will remain the only supported method

Agenda



- Evolution into an Enterprise Wide Solution

- GDPS V3.7 Enhancements
 - Improved coordinated disaster recovery across heterogeneous platforms
 - Improved scalability
 - Increased availability
 - Simplified system management

- Statements of Direction (SODs)

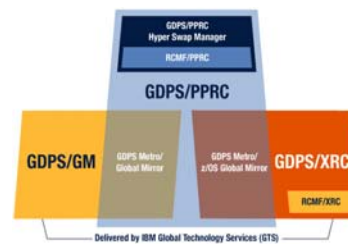

- Summary

Grow with GDPS



GDPS/PPRC

- ARZ
- Bancaja
- Bankinter
- BRZ
- Banca Popolare di Milano
- Bank of Montreal
- Deutsche Bank
- La Caixa
- Central Bank of Turkey
- Credit Suisse
- Danske Bank
- Deere & Company
- Finanz Informatik
- GAD
- Generali Informatik Services
- Halifax Bank of Scotland
- Monte Paschi di Siena
- IT-Austria
- Postbank
- Royal Bank of Scotland
- Sparda Bank (SDV)
- Svenska Handelsbanken
- Toronto Dominion Bank
- UBS
- and more

GDPS HyperSwap Manager

- Signal Iduna
- dm-drogerie markt

GDPS/XRC

- American Express
- Barclays Bank
- Key Bank
- Principal Financial Group
- Regions Financial Corp.
- Sun Trust Bank

More than 550 licenses in 38 countries
Dozens of references

Introduced in 1998
Over 12 years of experience

GDPS/MzGM

- Cedacri S.p.A.
- Garanti Bank
- ICBC
- Royal Bank of Canada
- Seceti
- UBS
- Wells Fargo

GDPS/MGM

- Baloise
- BPVN
- Credit Agricole
- Intesa Sanpaolo
- Six Group

GDPS HyperSwap Manager / zGM

- Commerzbank

GDPS installed in many of the largest banks in the world

GDPS V3.7 – Enterprise-wide CA and D/R solution



- Improved coordinated heterogeneous planned and unplanned events:
 - Extending the platforms supported
 - Already support IBM AIX, HP-UX, Linux, Sun Solaris, VMWare ESX
 - New: Microsoft Windows servers support added with GDPS V3.7
 - Multiple xDR enhancements *
 - Dynamic changes to GDPS/PPRC options without SA for MP refresh
 - Coordinated startup/shutdown of z/VM and guests
 - z/VM guests HyperSwap I/O timing trigger
 - Low impact initial copy / resync for distributed LUNs using GDPS/PPRC

* GDPS 3.7 timeframe



ibm.com/systems/z/gdps

GDPS
*The Enterprise-wide
Continuous Availability
and Disaster Recovery Solution*

GDPS V3.7 – Enterprise-wide CA and D/R solution (cont)



- Improved scalability:
 - UCB constraint relief with Metro Mirror secondary in alt subchannel set

- Increased availability:
 - GDPS/ Metro Global Mirror (GDPS/MGM) incremental resynchronization tool *
 - Reduces exposure from hours down to minutes

- Simplified system management:
 - Simpler installation / maintenance with less manual definitions
 - Freeze policy simplified and extended with additional options *
 - BCPii automatic reconnect
 - Additional GDPS Health Checks

* GDPS 3.7 timeframe

ibm.com/systems/z/gdps

GDPS
The Enterprise-wide
Continuous Availability
and Disaster Recovery Solution

59 © 2010 IBM Corporation

Summary

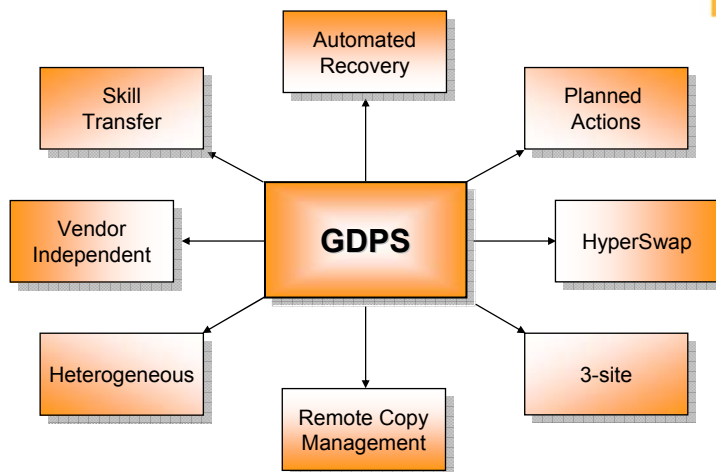

... more than 550 GDPS licenses in 38 countries,
dozens of references

Questions

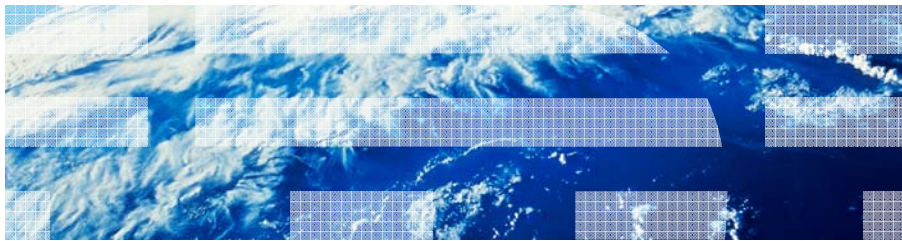

Dank u
Dutch

Merci
French

Спасибо
Russian

شكراً
Arabic

감사합니다
Korean

Tack så mycket
Swedish

धन्यवाद
Hindi

תודה רבה
Hebrew

Gracias
Spanish

谢谢
Chinese

Obrigado
Brazilian Portuguese

Dankon
Esperanto

Thank You

ありがとうございます
Japanese

Trugarez
Breton

Danke
German

Tak
Danish

Grazie
Italian

நன்றி
Tamil

děkuji
Czech

ขอขอบคุณ
Thai

go raibh maith agat
Gaelic